

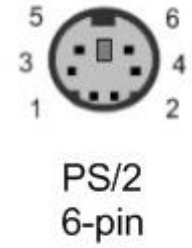

HABERLEŐME VE YÜKLEME KABLO ŐEMALARI

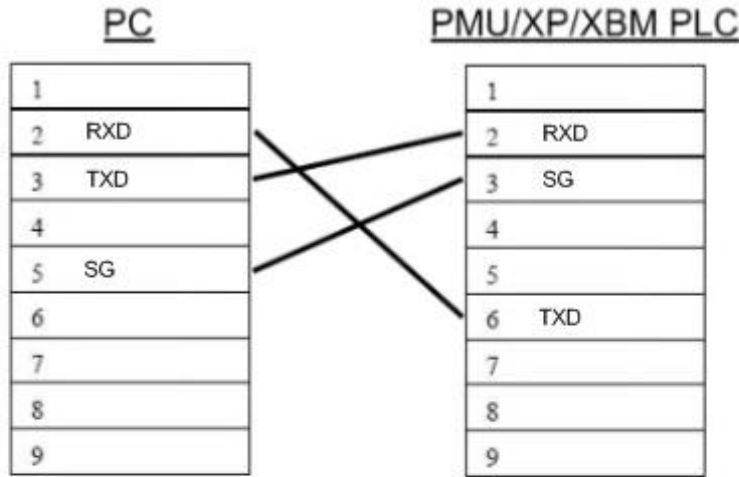

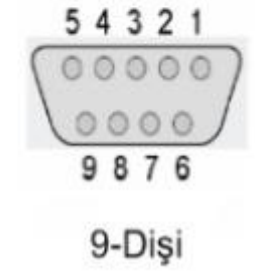
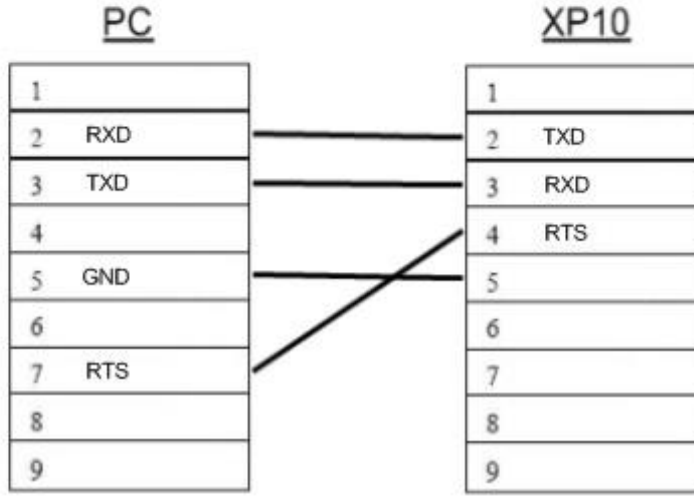
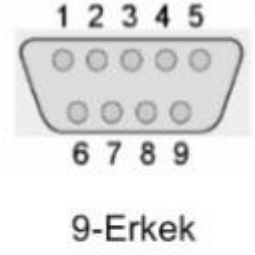
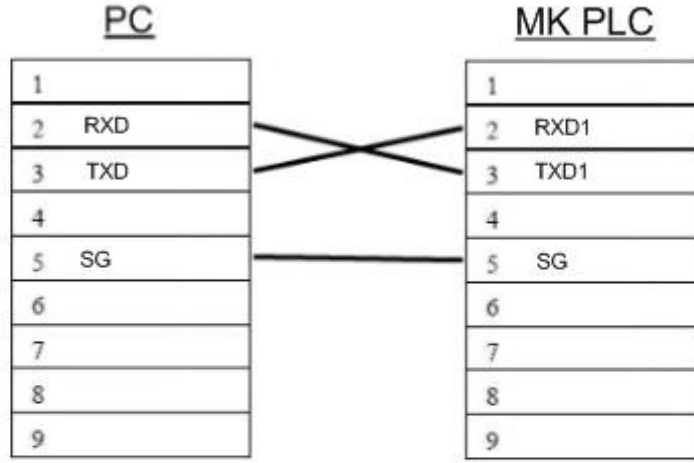

APARAT (PC-PLC kablosunu PC-PMU/XP/XBM kablosuna dönüştürür)

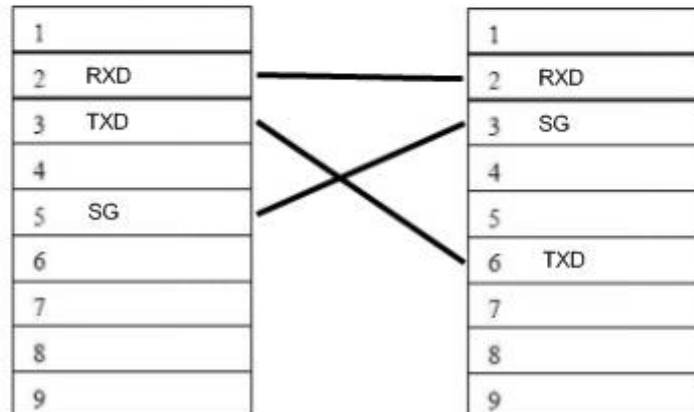
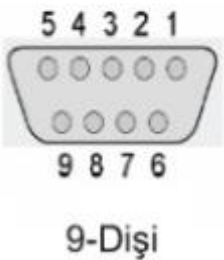



MK PLC (Loader)

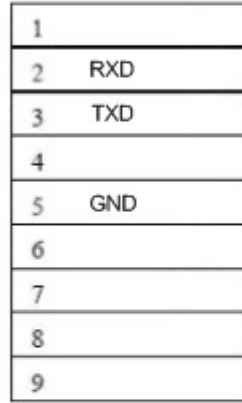

PMU 330

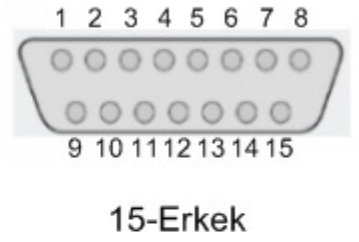
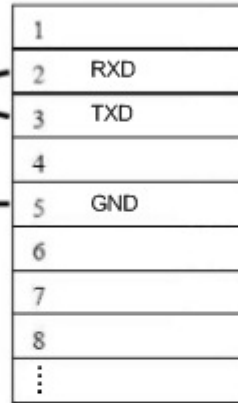

MK PLC (C-NET)

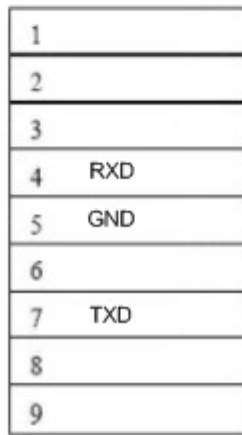
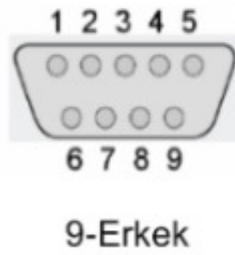

PMU 330

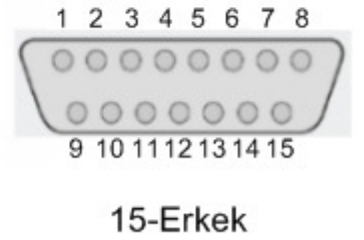
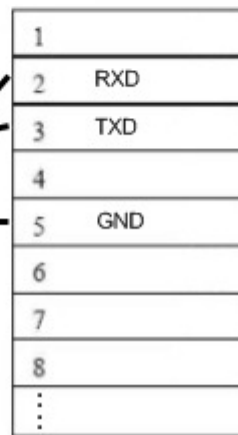

MK PLC (Loader)

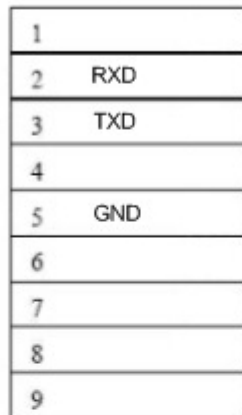

XP10

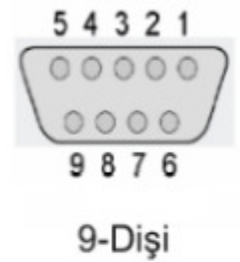
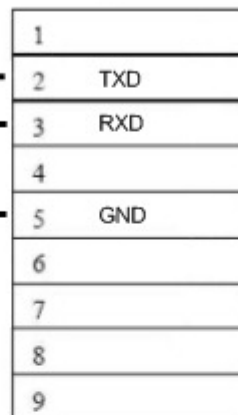

MK PLC (C-NET)

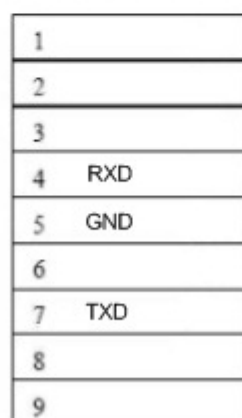
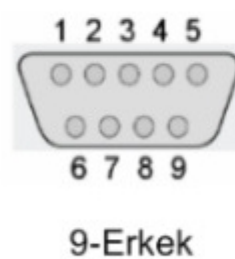

XP10

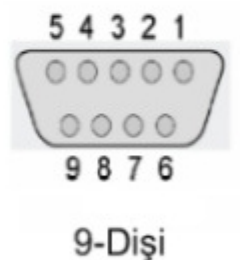
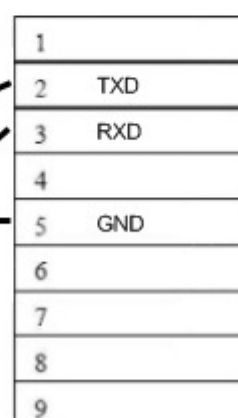

MK PLC (Loader)

XP Panel

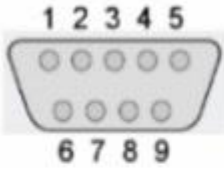

9-Erkek

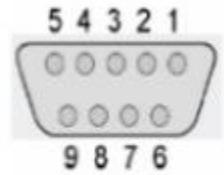
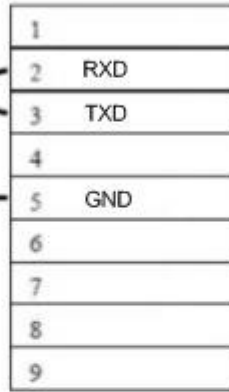
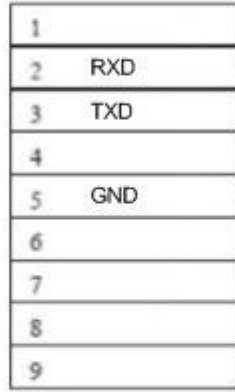

9-Dişi

MK PLC (C-NET)

XP Panel

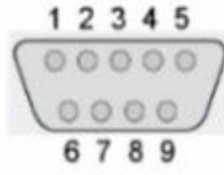

9-Erkek

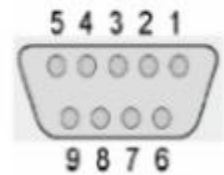
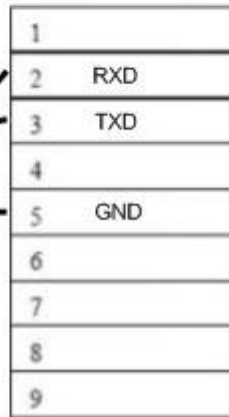
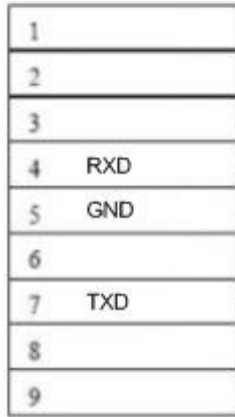

9-Dişi

PMU 330

XP Panel

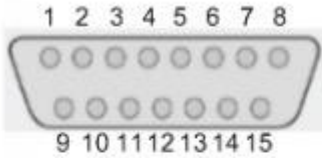

15-Erkek

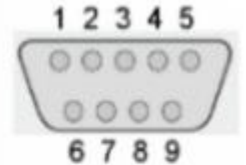
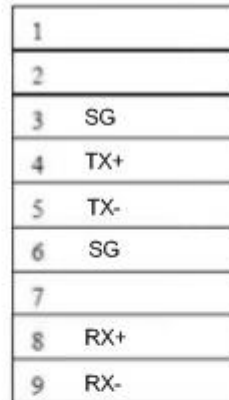
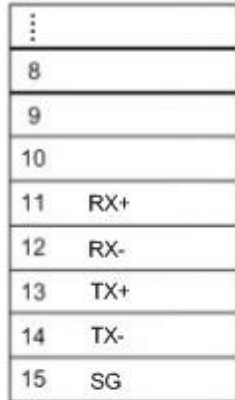

9-Erkek

* RS485 pin no.

XP Panel Ekonomik

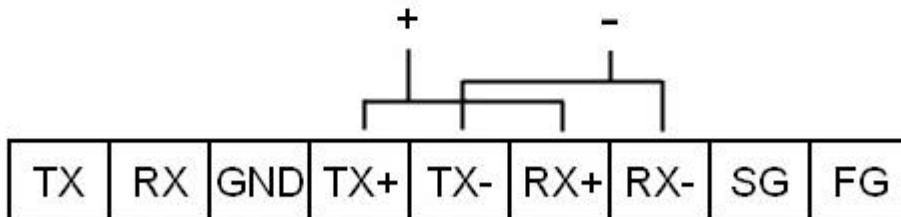

* RS485 pin no.

* Panele arkadan bakış

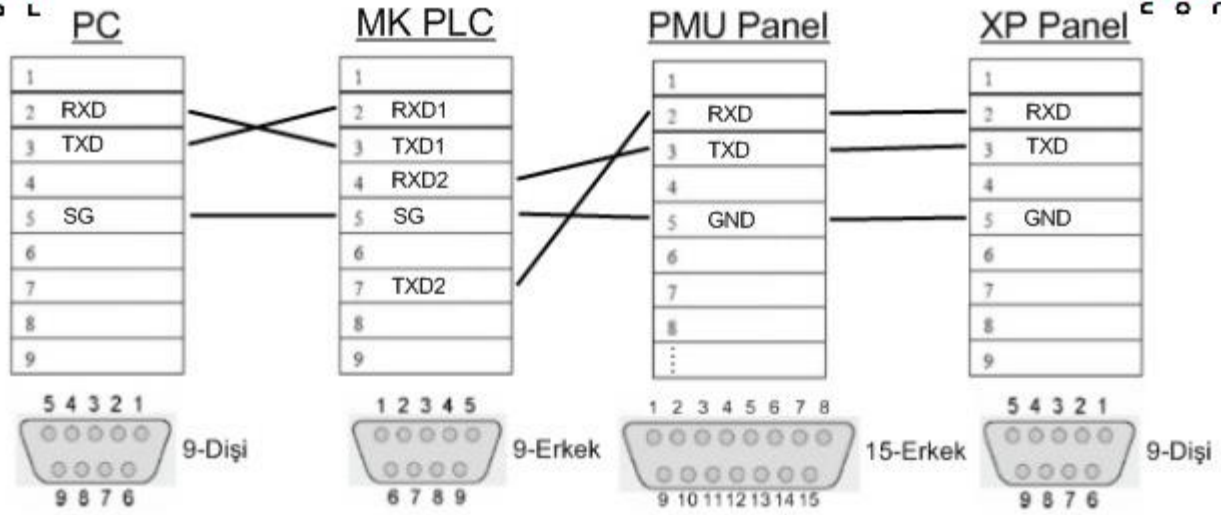

PROFIBUS GENEL BAĞLANTI

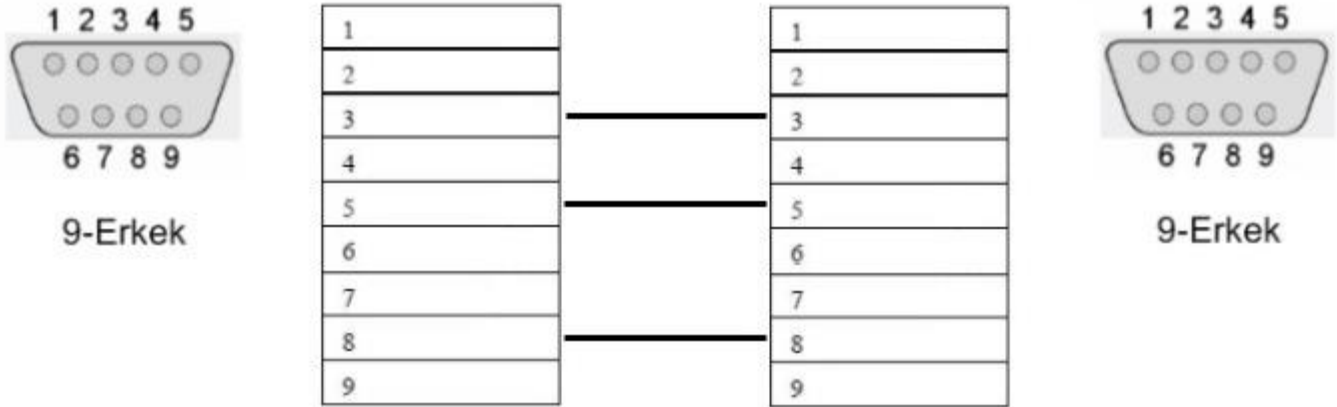

* Sürüm 1.12

* Tüm soketler önden (pinli taraftan) bakılarak çizilmiştir.

XGT PLC BAĞLANTI ŞEMALARI

C40HF-10PB-1B INPUT					C40HF-10PB-1B NPN/PNP OUTPUT						
TG7-1H40S	PLC I/O	PLC CONN.No.		PLC I/O	TG7-1H40S	PLC I/O	PLC CONN.No.		PLC I/O	TG7-1H40S	
B1	P0	B20	A20	P10	A1	B1	P0	B20	A20	P10	A1
B2	P1	B19	A19	P11	A2	B2	P1	B19	A19	P11	A2
B3	P2	B18	A18	P12	A3	B3	P2	B18	A18	P12	A3
B4	P3	B17	A17	P13	A4	B4	P3	B17	A17	P13	A4
B5	P4	B16	A16	P14	A5	B5	P4	B16	A16	P14	A5
B6	P5	B15	A15	P15	A6	B6	P5	B15	A15	P15	A6
B7	P6	B14	A14	P16	A7	B7	P6	B14	A14	P16	A7
B8	P7	B13	A13	P17	A8	B8	P7	B13	A13	P17	A8
B9	P8	B12	A12	P18	A9	B9	P8	B12	A12	P18	A9
B10	P9	B11	A11	P19	A10	B10	P9	B11	A11	P19	A10
B11	P0A	B10	A10	P1A	A11	B11	P0A	B10	A10	P1A	A11
B12	P0B	B09	A09	P1B	A12	B12	P0B	B09	A09	P1B	A12
B13	P0C	B08	A08	P1C	A13	B13	P0C	B08	A08	P1C	A13
B14	P0D	B07	A07	P1D	A14	B14	P0D	B07	A07	P1D	A14
B15	P0E	B06	A06	P1E	A15	B15	P0E	B06	A06	P1E	A15
B16	P0F	B05	A05	P1F	A16	B16	P0F	B05	A05	P1F	A16
B17	NC	B04	A04	NC	A17	B17	NC	B04	A04	NC	A17
B18	NC	B03	A03	NC	A18	B18	NC	B03	A03	NC	A18
B19	COM	B02	A02	COM	A19	B19	DC12	B02	A02	0V	A19
B20	COM	B01	A01	COM	A20	B20	/24V	B01	A01	0V	A20

C40HF-10PB-1 NPN OUTPUT					C40HF-10PB-3 özel bağlantı				
R32C-NS5A -40P (NPN)	PLC I/O	PLC CONN.No.		PLC I/O	R32C-NS5A -40P (NPN)	TG7-1H40S	PLC CONN.No.		TG7-1H40S
P0	P0	B20	A20	P10	P10	A1	1	2	B1
P1	P1	B19	A19	P11	P11	A2	3	4	B2
P2	P2	B18	A18	P12	P12	A3	5	6	B3
P3	P3	B17	A17	P13	P13	A4	7	8	B4
P4	P4	B16	A16	P14	P14	A5	9	10	B5
P5	P5	B15	A15	P15	P15	A6	11	12	B6
P6	P6	B14	A14	P16	P16	A7	13	14	B7
P7	P7	B13	A13	P17	P17	A8	15	16	B8
P8	P8	B12	A12	P18	P18	A9	17	18	B9
P9	P9	B11	A11	P19	P19	A10	19	20	B10
P0A	P0A	B10	A10	P1A	P1A	A11	21	22	B11
P0B	P0B	B09	A09	P1B	P1B	A12	23	24	B12
P0C	P0C	B08	A08	P1C	P1C	A13	25	26	B13
P0D	P0D	B07	A07	P1D	P1D	A14	27	28	B14
P0E	P0E	B06	A06	P1E	P1E	A15	29	30	B15
P0F	P0F	B05	A05	P1F	P1F	A16	31	32	B16
NC	NC	B04	A04	NC	NC	A17	33	33	B17
NC	NC	B03	A03	NC	NC	A18	35	36	B18
+24V	DC12/24V	B02	A02	COM	-24G	A19	37	38	B19
+24V	DC12/24V	B01	A01	COM	-24G	A20	39	40	B20